

# Lexington County Planning Commission

## ACCESS POLICY

*Revised*  
06-10-2009

### PURPOSE:

This access policy is established to guide the Community Development staff as they interpret and enforce the Lexington County Subdivision Regulations relative to the manner and extent of subdivision allowed without the provision of new roads. This policy will be implemented by the staff with any proposed variances in this policy presented to the Planning Commission for a vote.

This policy has also been established to ensure thoughtful subdivision that does not needlessly burden existing roads. It takes steps to ensure that landowners have accessible, maintainable driveways. Factors such as elevation, drainage, slope, direction, velocity, and quantity of water will be taken into account in determining the suitability of a flag lot or access easement. In addition, the ability for two vehicles to safely pass or an emergency vehicle to traverse the road will be considered.

A primary concern will be minimizing potential damage to a public road right-of-way. The maintainability of the flag lot or access easement serving as a driveway will be a secondary concern.

### CRITERIA:

On the following pages are the specific criteria of this Access Policy along with corresponding figures illustrating their meaning and application. These criteria are intended to apply cumulatively; that is, all criteria must be satisfied.

As indicated above, in addition to the specific access criteria, the stability and maintenance of the driveway will be addressed during staff review. The slope, soil, type, and length of the driveway will be taken into consideration, as well as the volume, velocity, and direction of the stormwater runoff.

Driveways meeting this access policy will typically be designed with a maximum slope of 5–10 percent, based on the soil type and demonstrated water velocity. If the required slope cannot be met, stabilization measures will be required wherever possible. The access should slope away from any intersecting publicly-maintained road.

### DEFINITIONS:

Access – A way or means of approach to provide physical entrance to a property.

Access easement – A property right for vehicular access granted by one parcel owner to an adjacent property owner.

Driveway – A vehicular access connecting a single parcel (and potentially a second parcel via an access easement) to a road.

Road – A vehicular access (which is recognized by the county as publicly or privately maintained) serving three or more parcels.

Landlocked parcel – A parcel which does not have fee simple title frontage on a road right-of-way.

Flag lot – A lot without fee simple title frontage on a road right-of-way except for a narrow strip of land serving as a driveway.

Sight distance – The minimum distance measured from a stopped vehicle at an intersection which allows the driver to see approaching traffic from both directions without obstruction.

1.

Any part of a proposed subdivision that accesses a state-maintained road must comply with the provisions set forth by the South Carolina Department of Transportation. An approved encroachment permit for such access must be submitted to the County of Lexington prior to the approval of a subdivision plat.

For information on SCDOT requirements, please refer to:

ACCESS AND ROADSIDE MANAGEMENT STANDARDS

Published by the South Carolina Department of Transportation

Traffic Engineering

955 Park Street, PO Box 191

Columbia, SC 29202-0191

[www.scdot.org](http://www.scdot.org)

For information on encroachment permits, please contact:

South Carolina Department of Transportation

District One Engineering

Lexington Maintenance Office

(803) 359-4103

2.

If an access easement is used to provide a driveway for a landlocked parcel, that access easement may only be designated over one parcel.

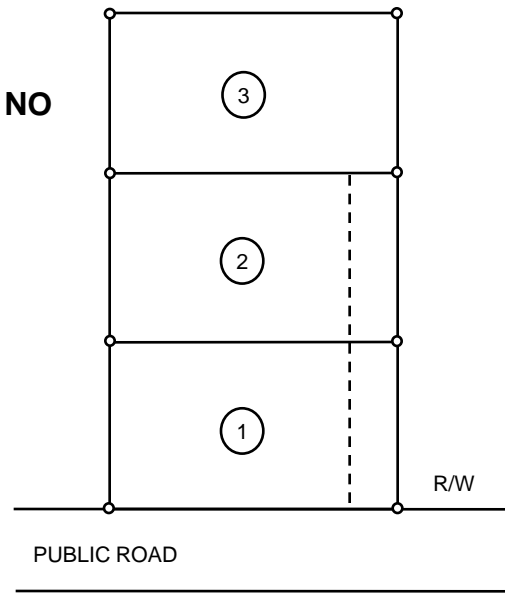
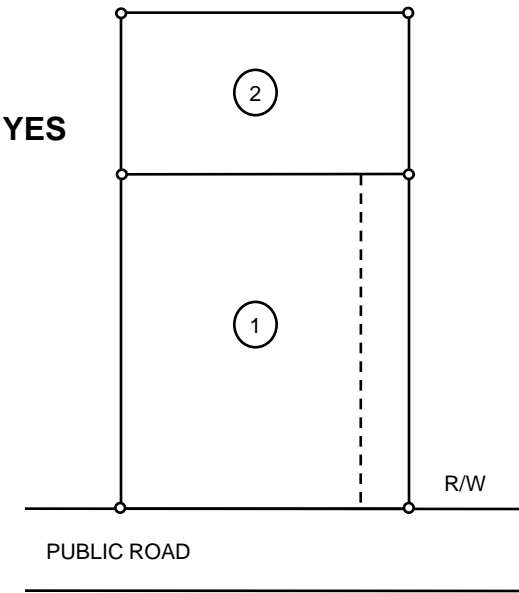

3.

If an access easement is used to provide a driveway for a landlocked parcel, that access easement may not serve another landlocked parcel.

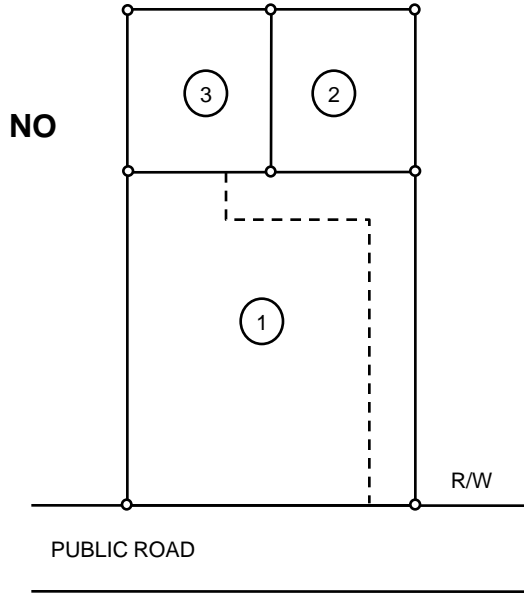
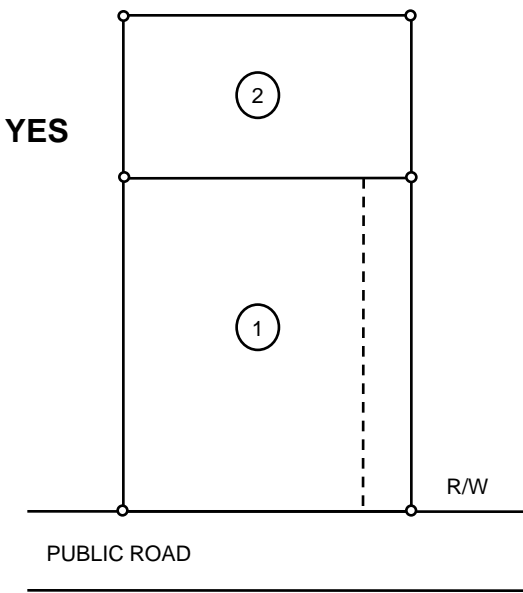

4.

An access easement serving a landlocked parcel less than 2 acres shall be at least 20 feet wide along its entire length.

YES

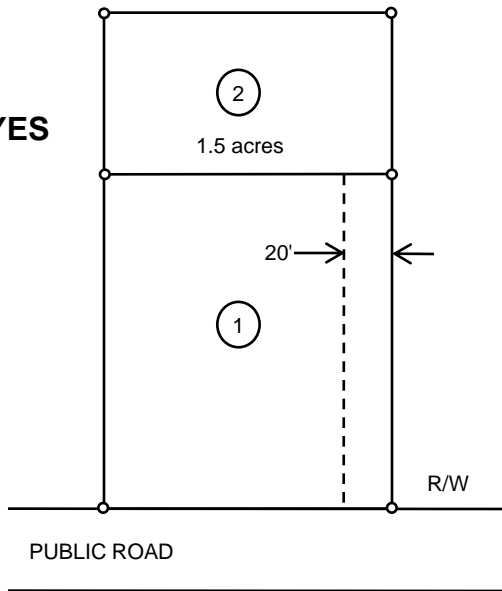

NO

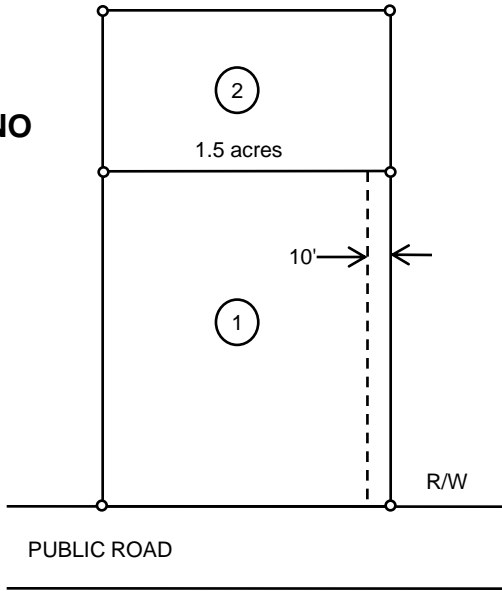

5.

The driveway portion of a flag lot serving a parcel less than 2 acres shall be at least 20 feet wide along its entire length.

YES

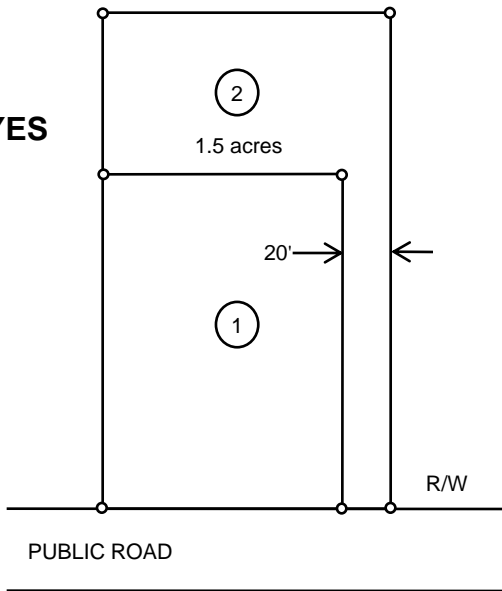

NO

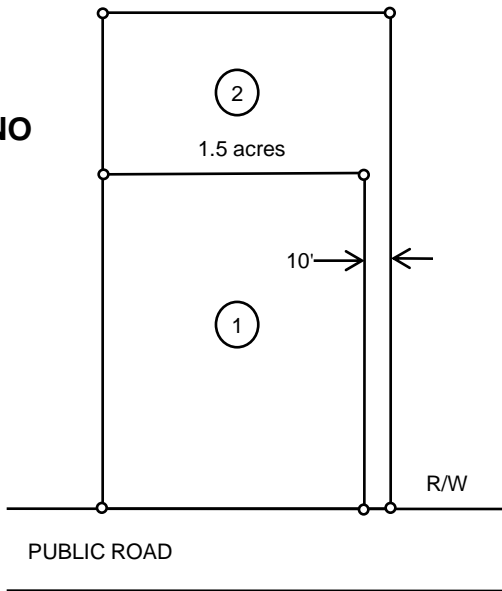

6.

An access easement serving a 2 acre or larger landlocked parcel shall be at least 50 feet wide along its entire length.

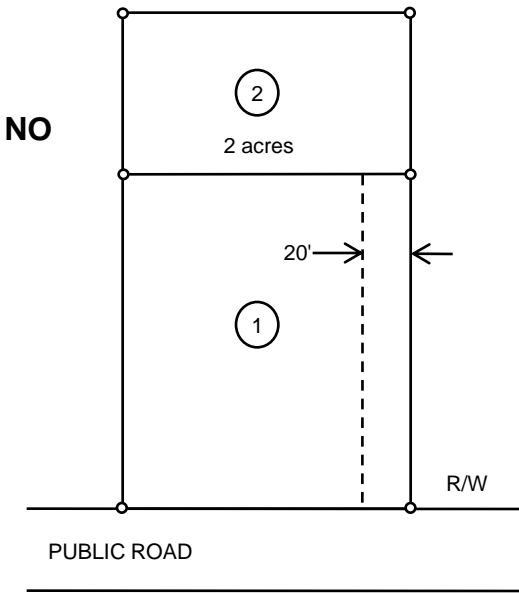
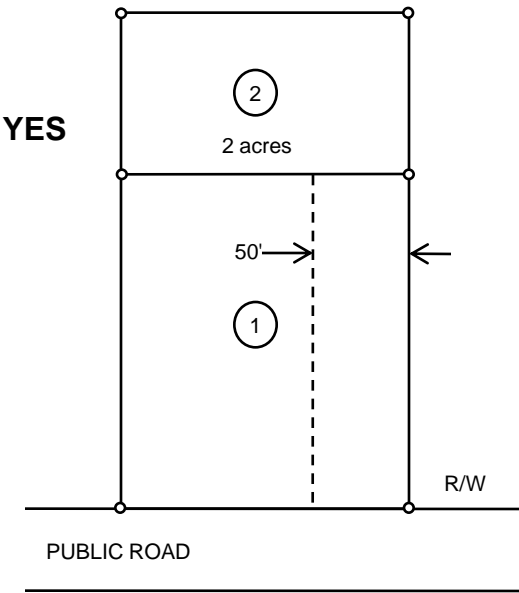

7.

The driveway portion of a 2 acre or larger flag lot shall be at least 50 feet wide along its entire length.

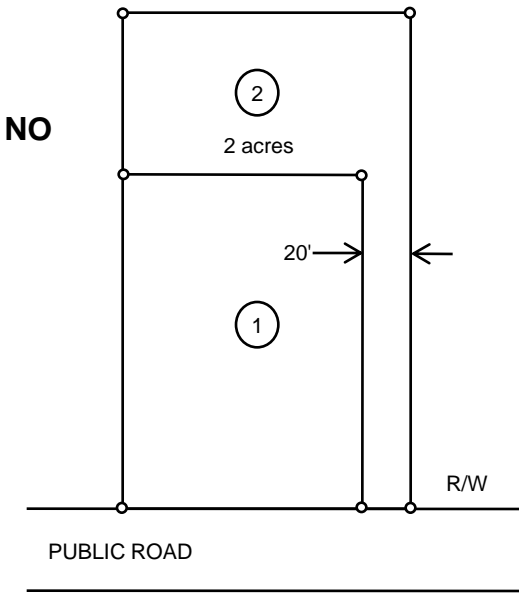
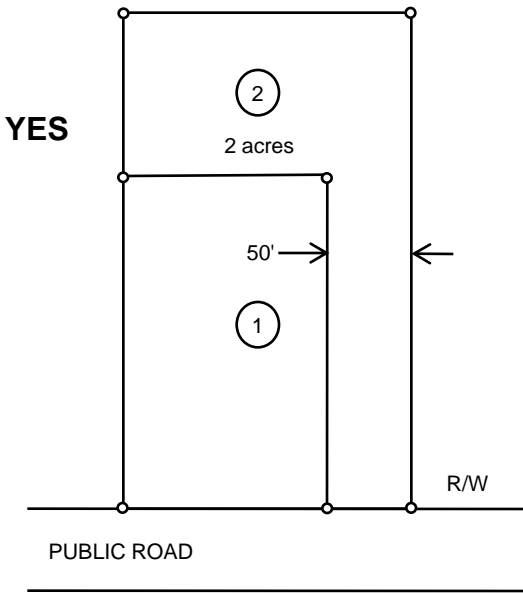

8.

An access easement serving a 2 acre or larger landlocked parcel shall be directly aligned with or separated at least 150 feet from any existing or proposed "Local" road, as measured from centerline to centerline. If the existing or proposed road is a "Collector" road then the required separation is 175 feet. For an "Arterial" road the minimum distance is 200 feet. Adequate sight distance shall be provided from the driveway along the intersecting road right-of-way, and the access easement shall have an angle of intersection of not less than 75 degrees.

YES

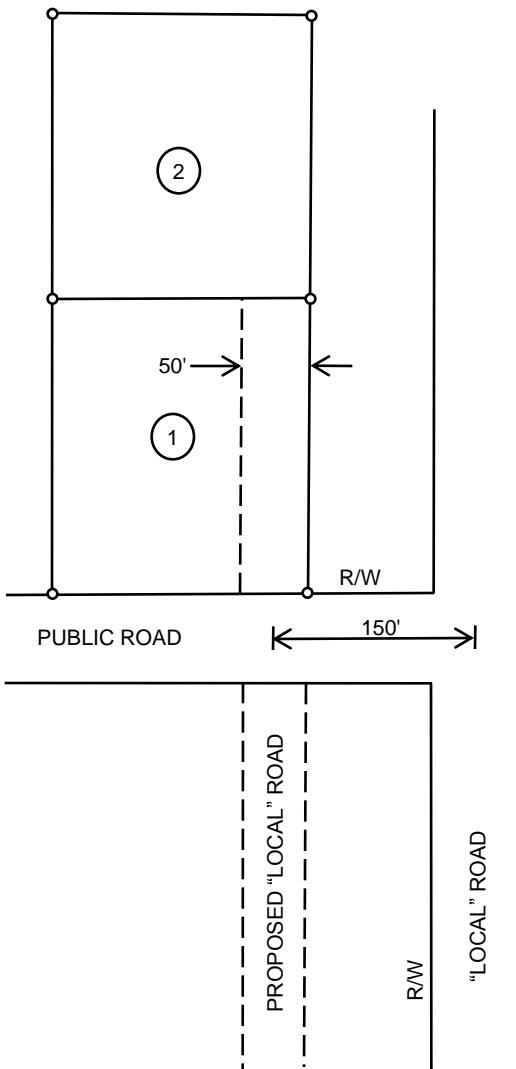

NO

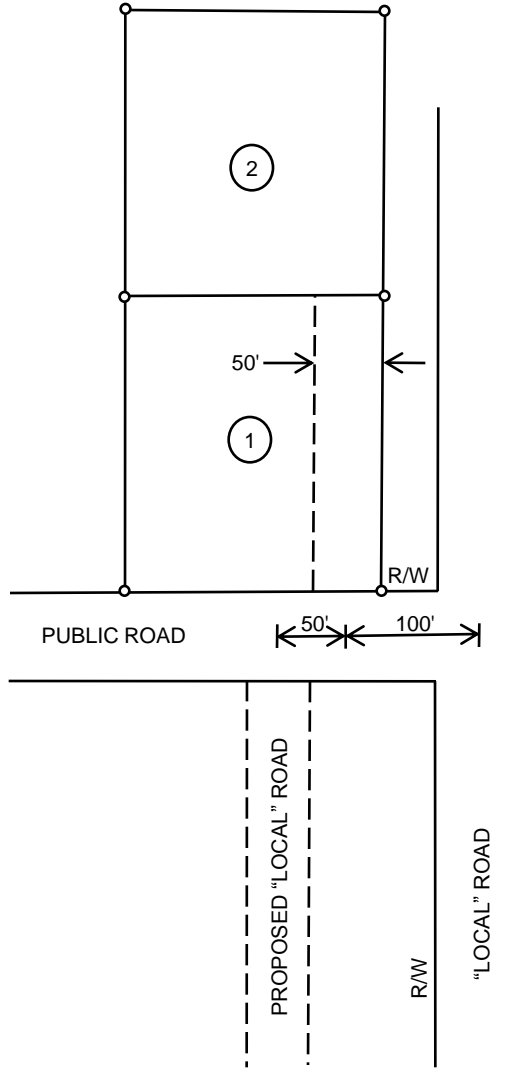

9.

The driveway portion of a 2 acre or larger landlocked parcel shall be directly aligned with or separated at least 150 feet from any existing or proposed "Local" road, as measured from centerline to centerline. If the existing or proposed road is a "Collector" road then the required separation is 175 feet. For an "Arterial" road the minimum distance is 200 feet. Adequate sight distance shall be provided from the driveway along the intersecting road right-of-way, and the access easement shall have an angle of intersection of not less than 75 degrees.

YES

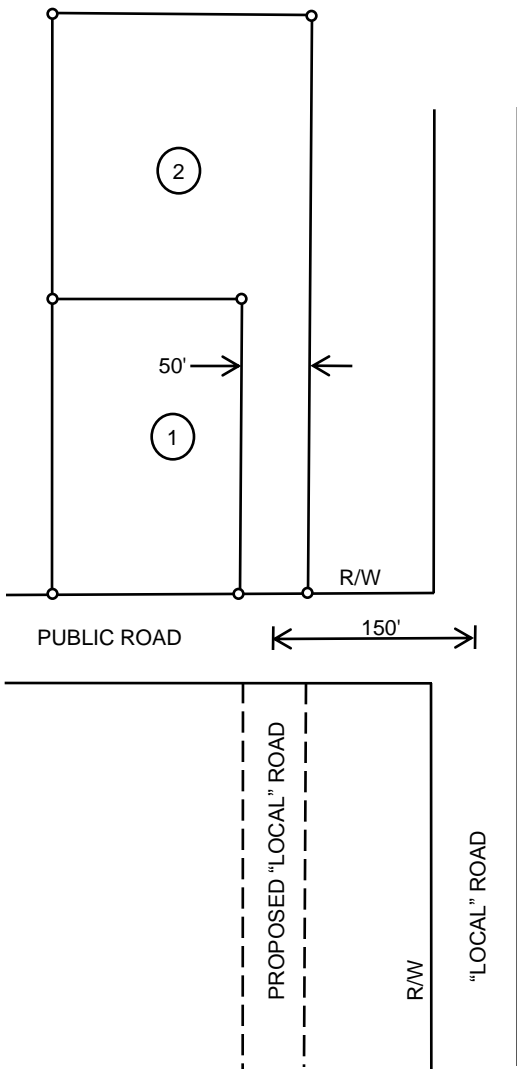

NO

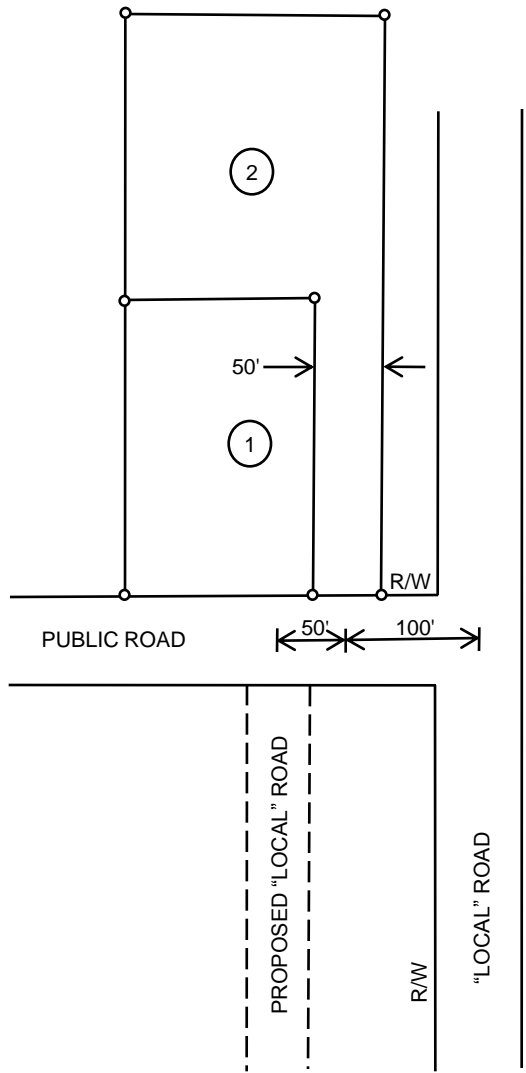

10.

An access easement serving a landlocked parcel may not be contiguous to an access easement serving another landlocked parcel unless both landlocked parcels are less than 2 acres each.

YES

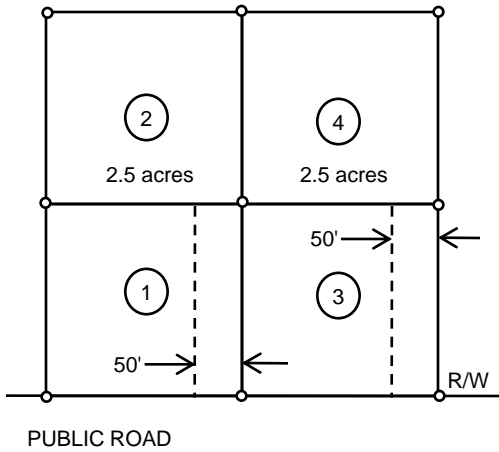

NO

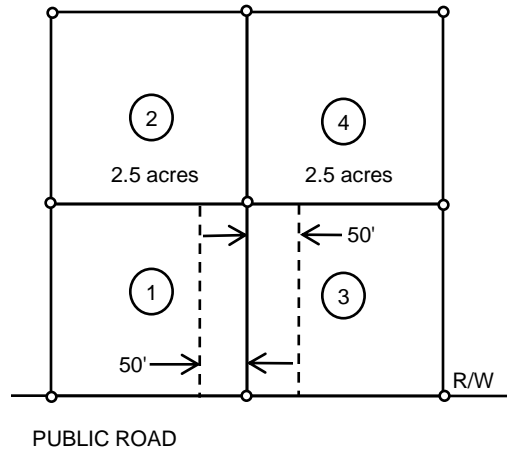

YES

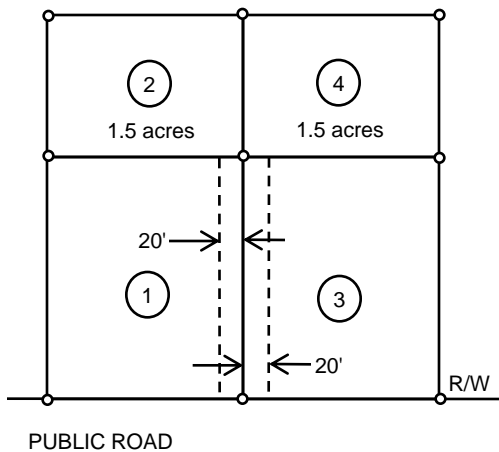

NO

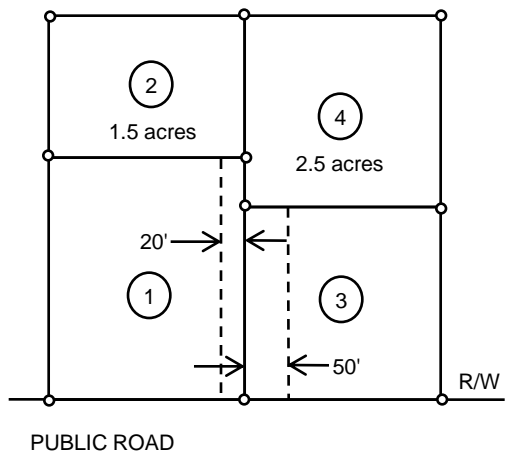

11.

An access easement serving a landlocked parcel may not be contiguous to the driveway portion of a flag lot unless both parcels are less than 2 acres each. The driveway portion of a flag lot so paired may not serve as an access easement for another parcel.

**YES**

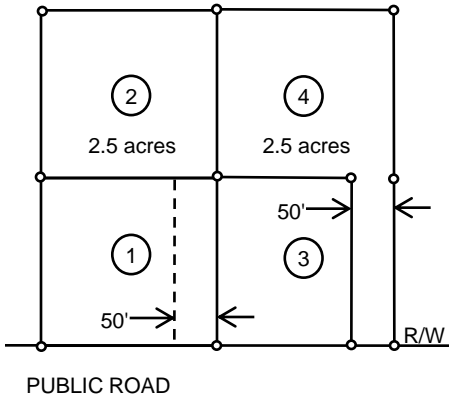

**NO**

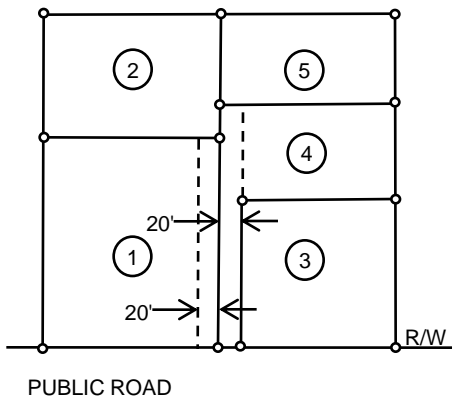
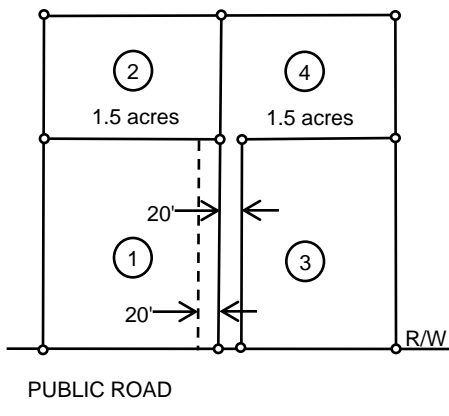
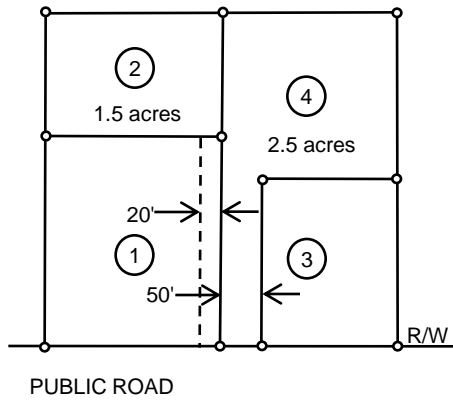
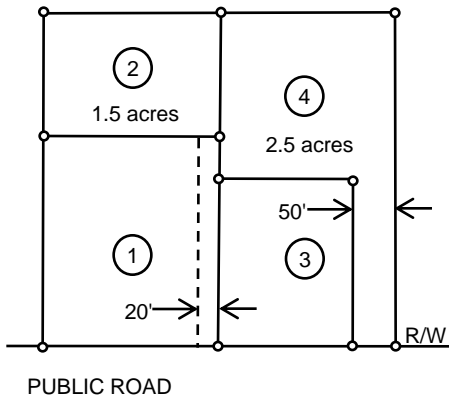
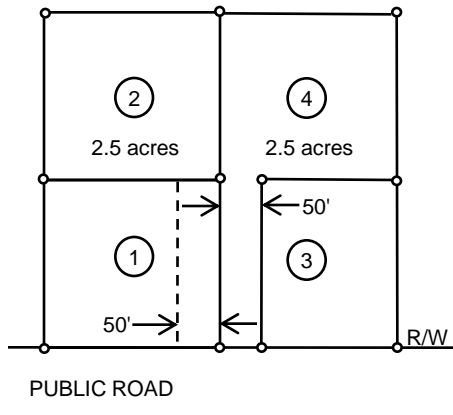

12.

The driveway portion of a flag lot may not be contiguous to the driveway portion of another flag lot unless both flag lots are less than 2 acres each. The driveway portion of flag lots so paired may not serve as access easements for other parcels.

YES

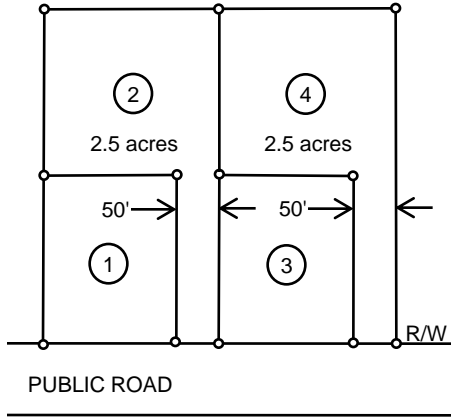

NO

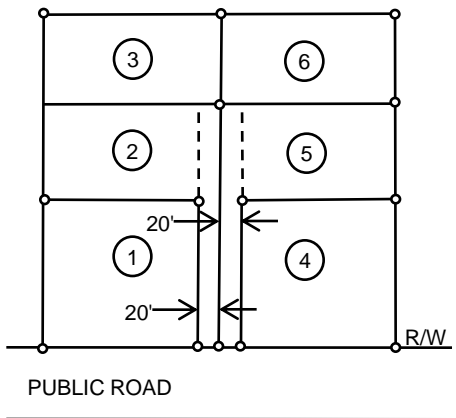
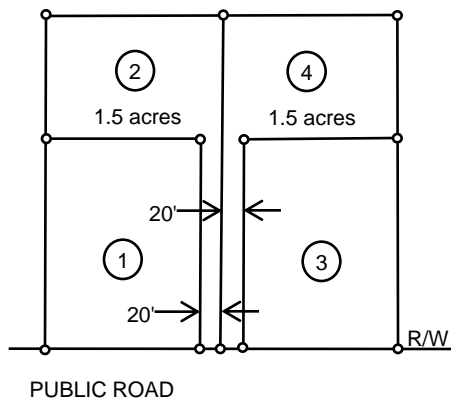
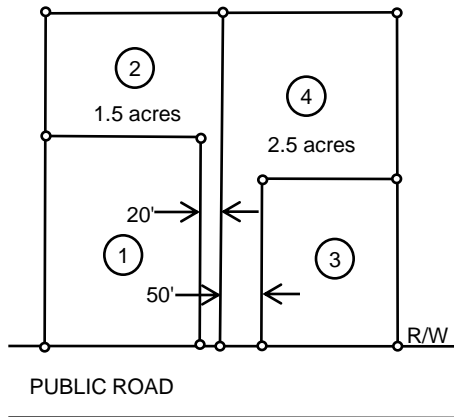
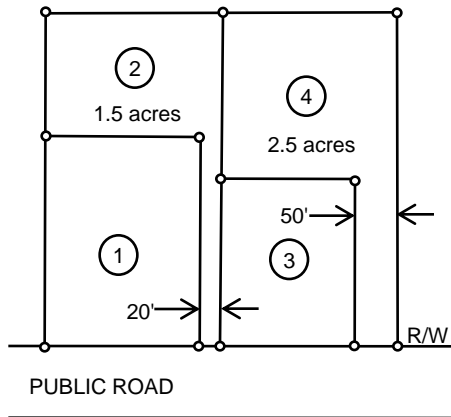
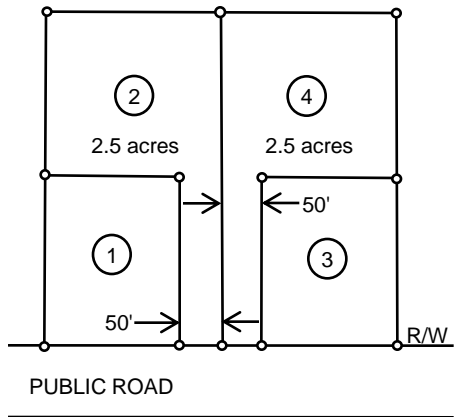

13.

Successive access easements or flag lot driveways, whether single or paired, along a continuous road right-of-way boundary shall be separated by at least one parcel with a minimum of 100 feet of frontage along the same road right-of-way boundary.

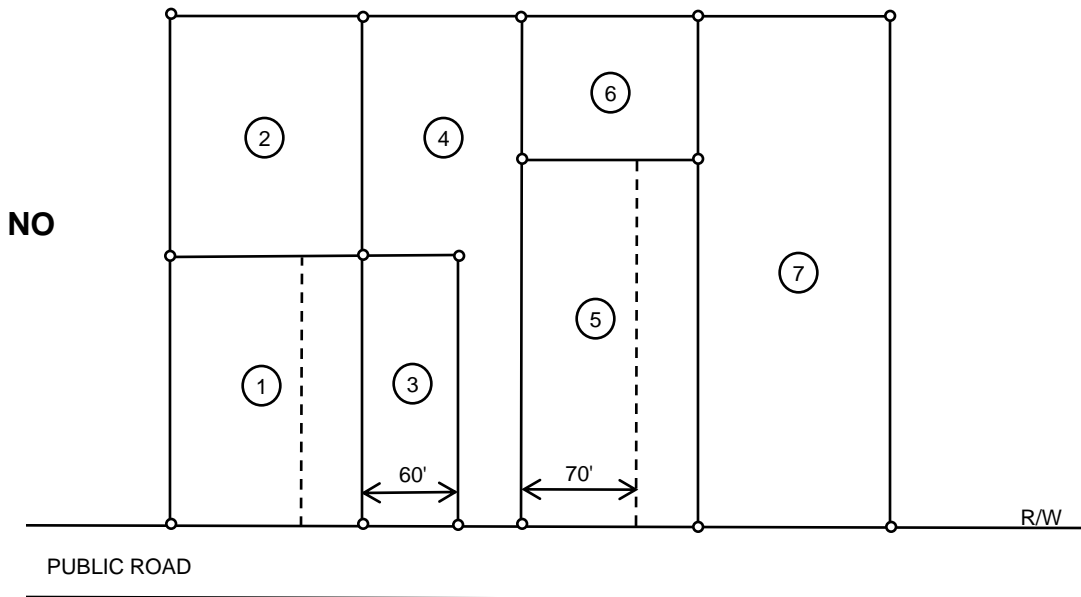
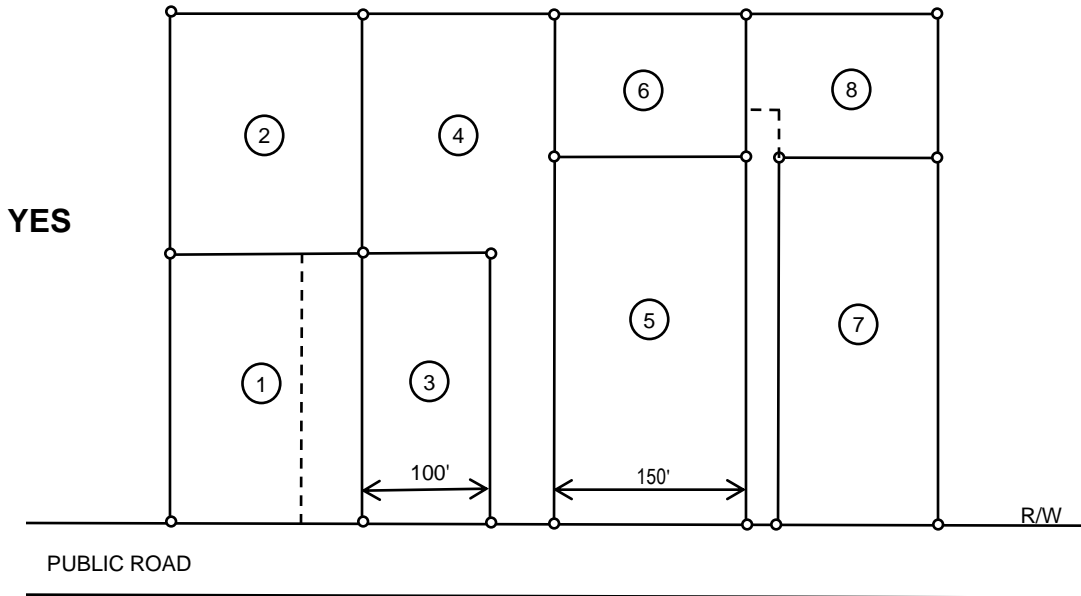

14.

Four-tiered parcels are not allowed. No more than two three-tiered groups of parcels served by access easements or flag lot driveways may be allowed at the same location, as part of the same overall development plan.

YES

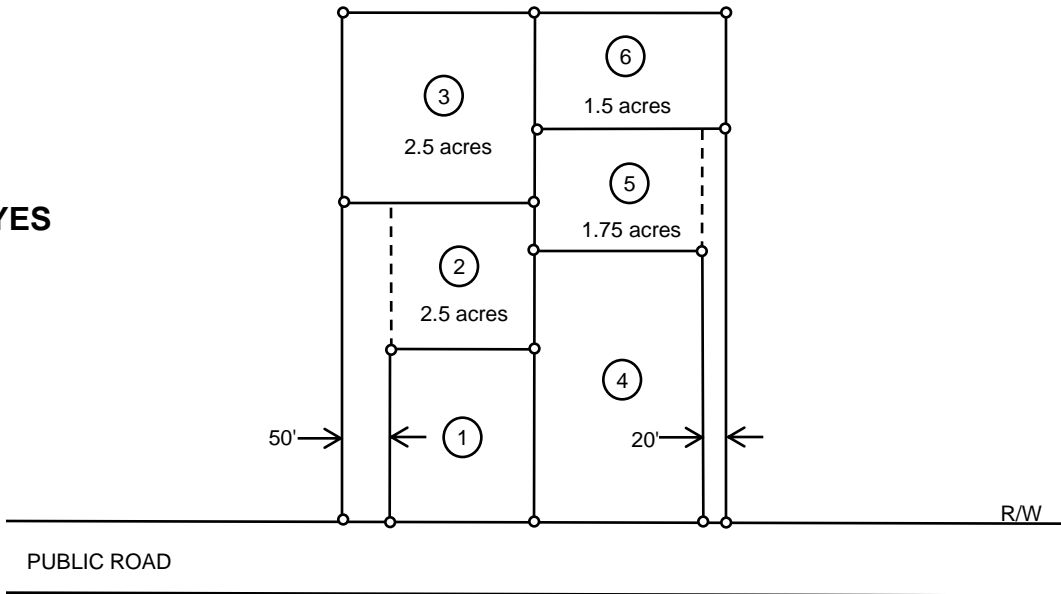

NO

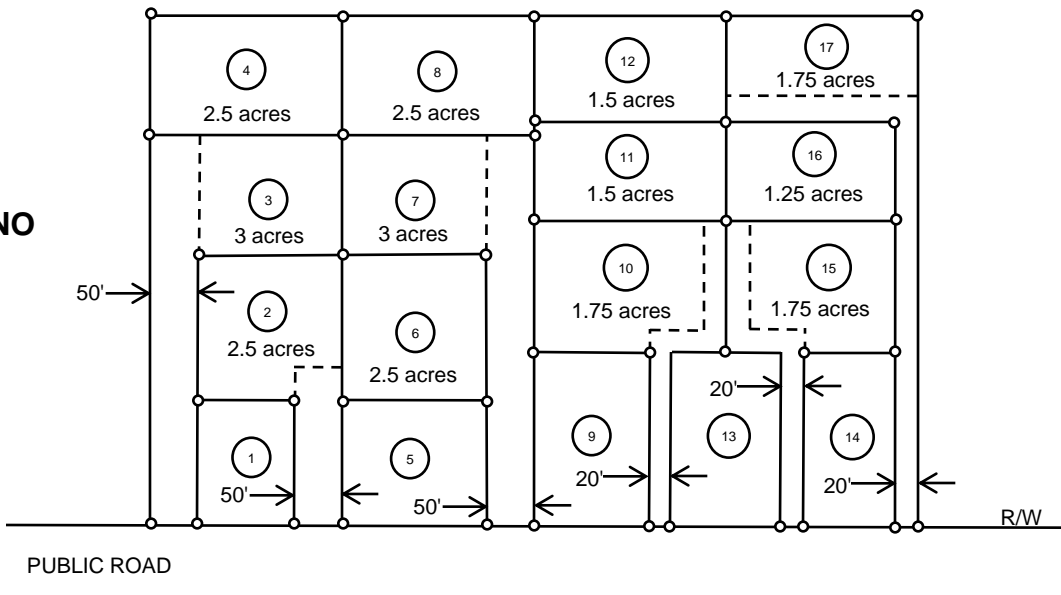

15.

Successive access easements or flag lot driveways (more than two at the same location) may be no more than two tiers behind the road right-of-way that is being accessed. Parcels meeting this policy will be designed to minimize the number of access points to the main road.

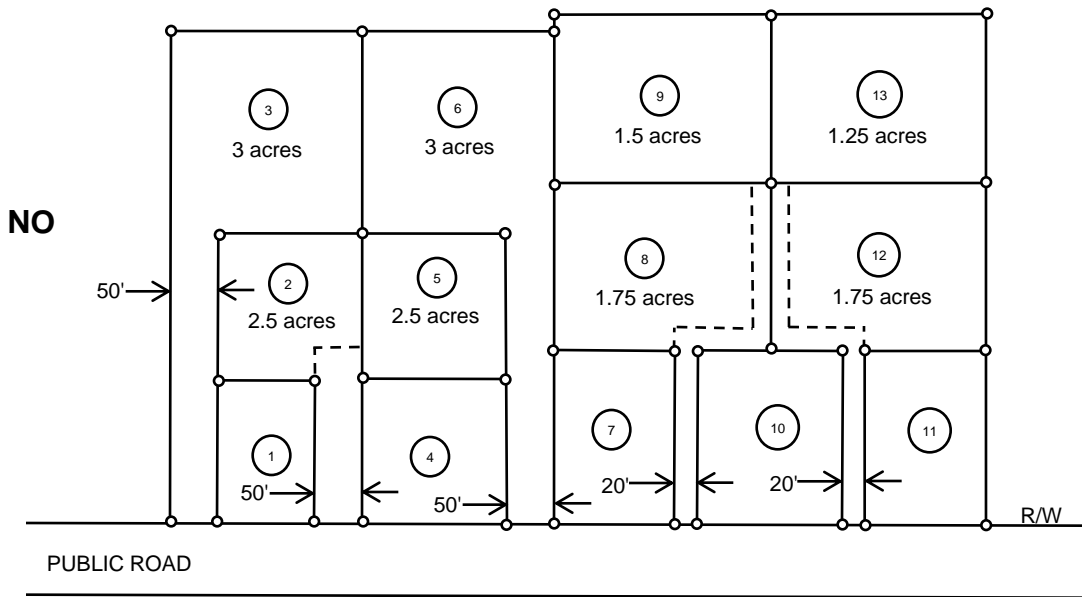
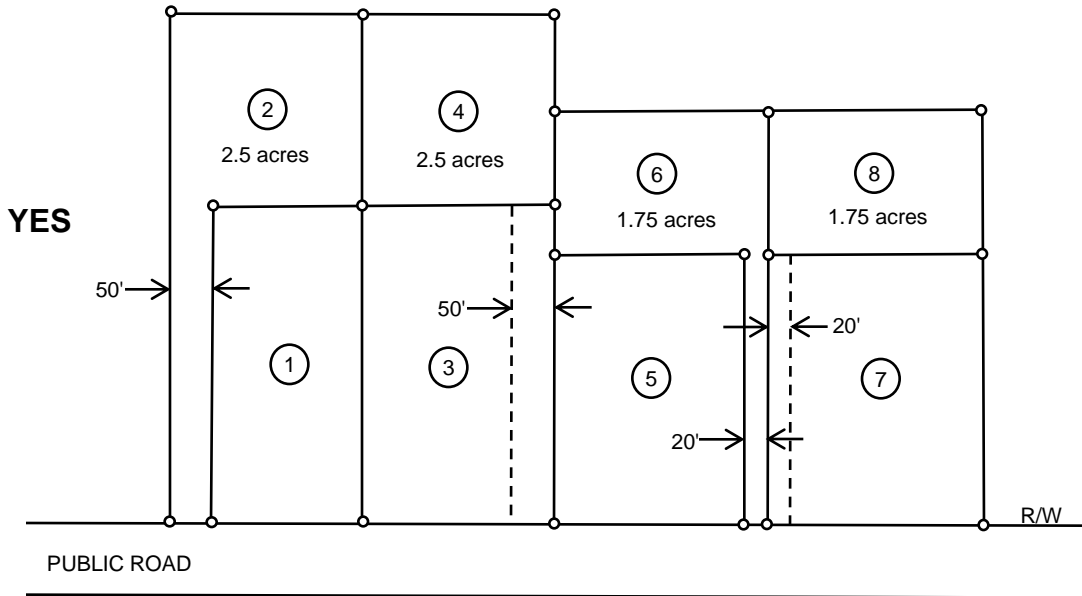

16.

Neither an access easement nor a driveway portion of a flag lot shall exceed 1500 feet in total length, except on the basis that the accessed parcel shall not be further subdivided. (Staff, in its discretion, may refer such plats to the planning commission for approval.)

YES

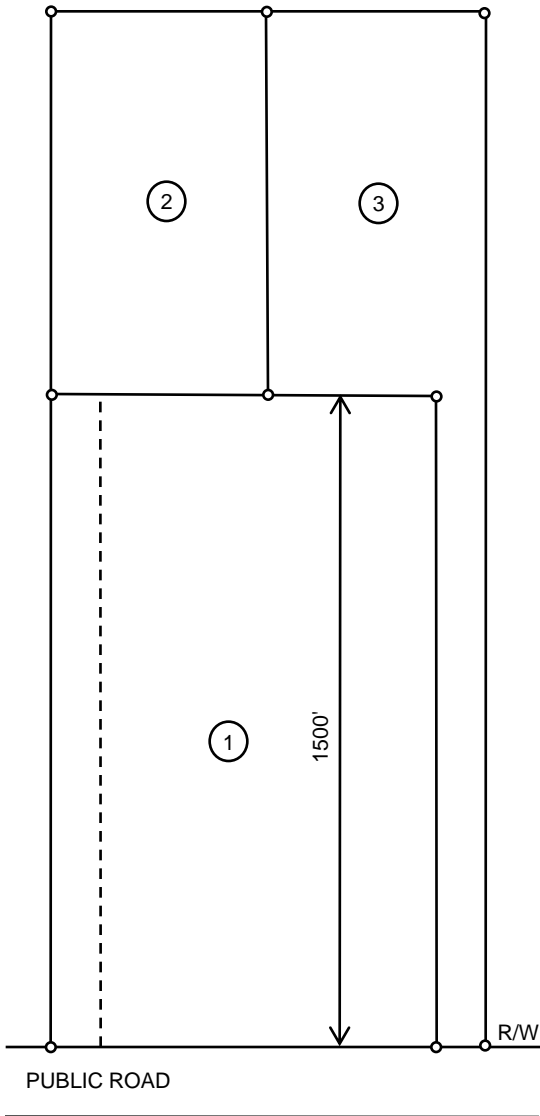

NO

